

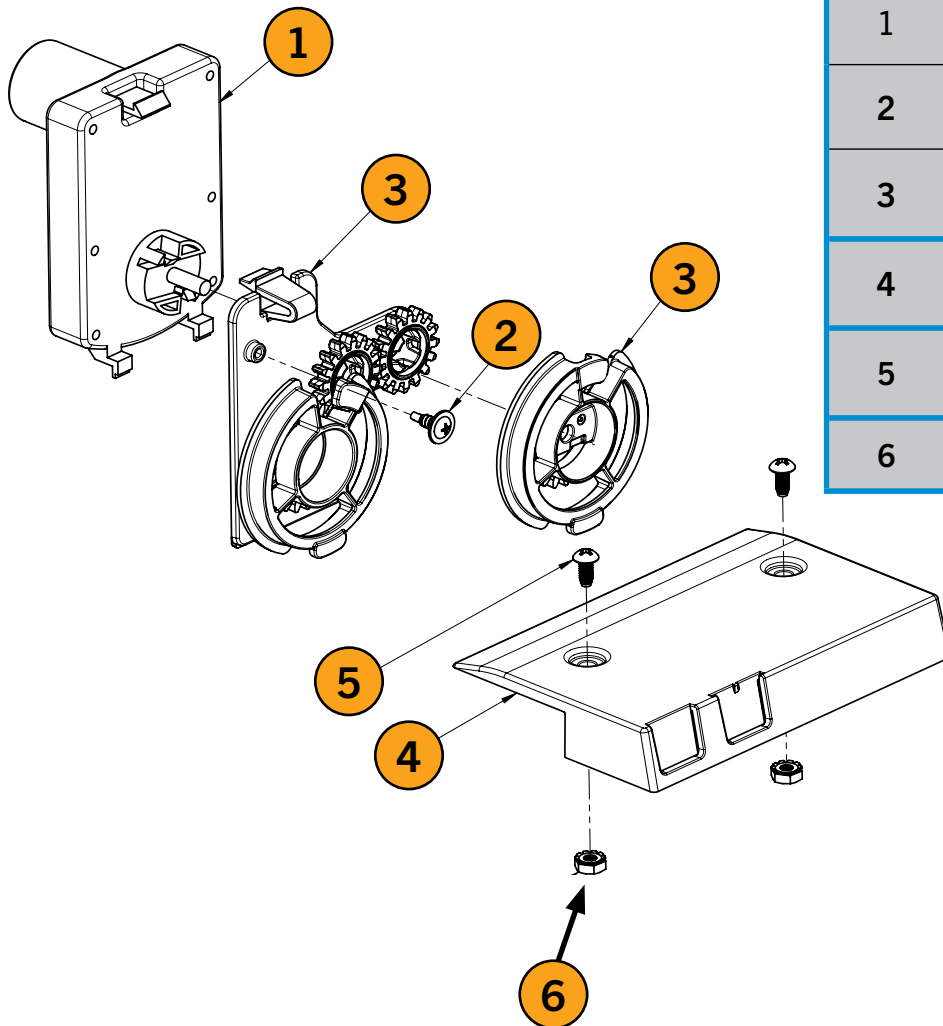

## GEAR DRIVE ASSEMBLY KIT INSTRUCTIONS

AP Dual Spiral 6000 - 7000 – Kit No. VE1020858 - Motor



#	PART NUMBER	DESCRIPTION	QUANTITY
1	VE2995	Vend Motor	1
2	VE9323B	SELF DRILLING SCREW	1
3	VE1016272	GEAR SET WITH LOOSE HUB COMPONENT	1
4	VE1017140	DUAL COIL TRAY NOSE	1
5	VE4317	SCREW, 8-32 X .375	2
6	VE7207K	NUT, 8-32	2

Any coils mentioned in this document are ordered separately from these kits.

**Please read the following instructions to install this kit on your tray.**

Remove the kit from its packaging and check for any missing parts or quality issues. If any parts are missing or damaged, contact Vendors Exchange at the number below.



## QUICK REFERENCE GUIDE

# GEAR DRIVE ASSEMBLY KIT INSTRUCTIONS

*AP Dual Spiral 6000 - 7000 – Kit No. VE1020858 - Motor*

**\*\* BEFORE YOU START PLEASE ENSURE THE COMPATIBILITY OF YOUR DUAL DRIVE KIT \*\***

**Not Compatible** ❌

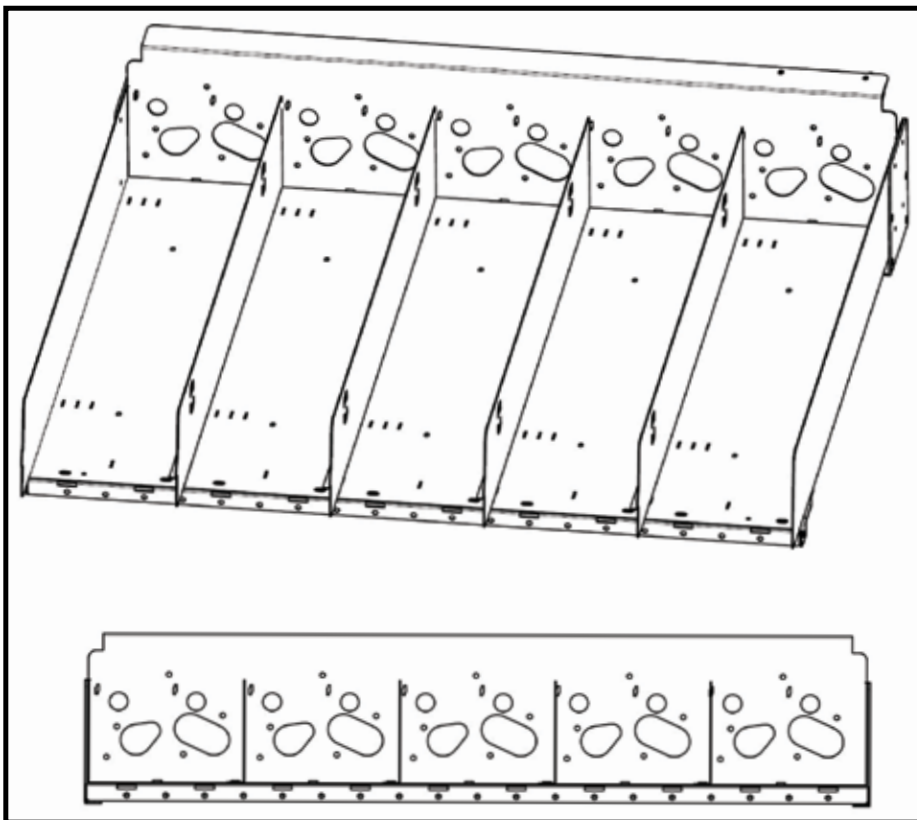

**Compatible** ✅

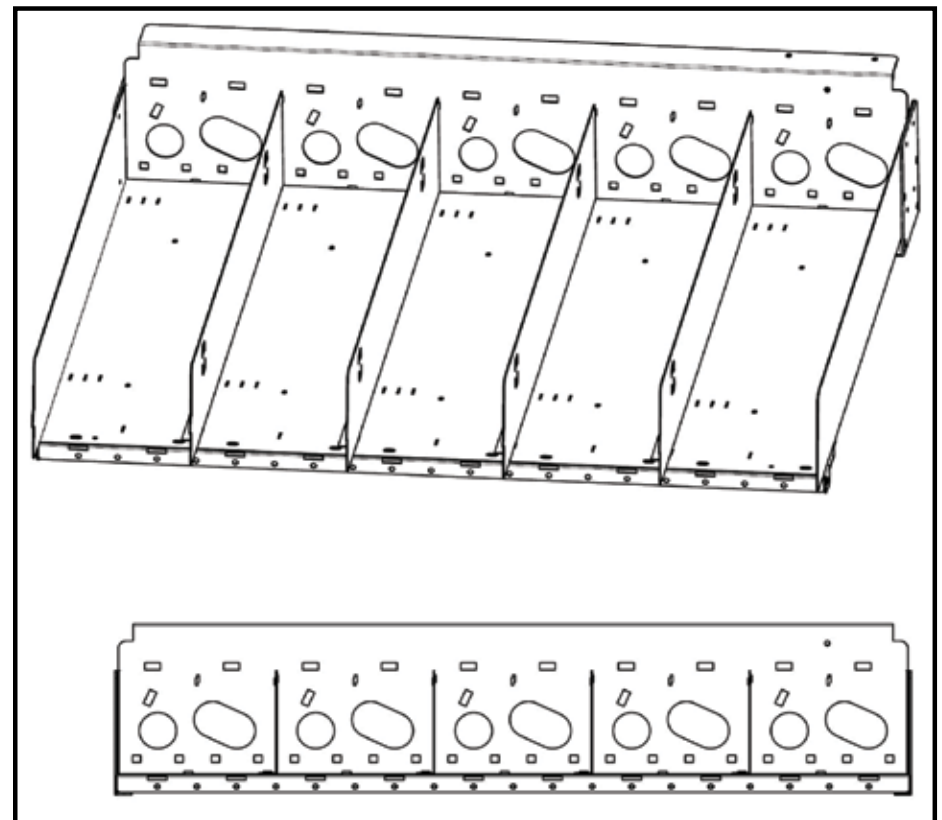



# GEAR DRIVE ASSEMBLY KIT INSTRUCTIONS

*AP Dual Spiral 6000 - 7000 – Kit No. VE1020858 - Motor*

## Tray Nose Installation

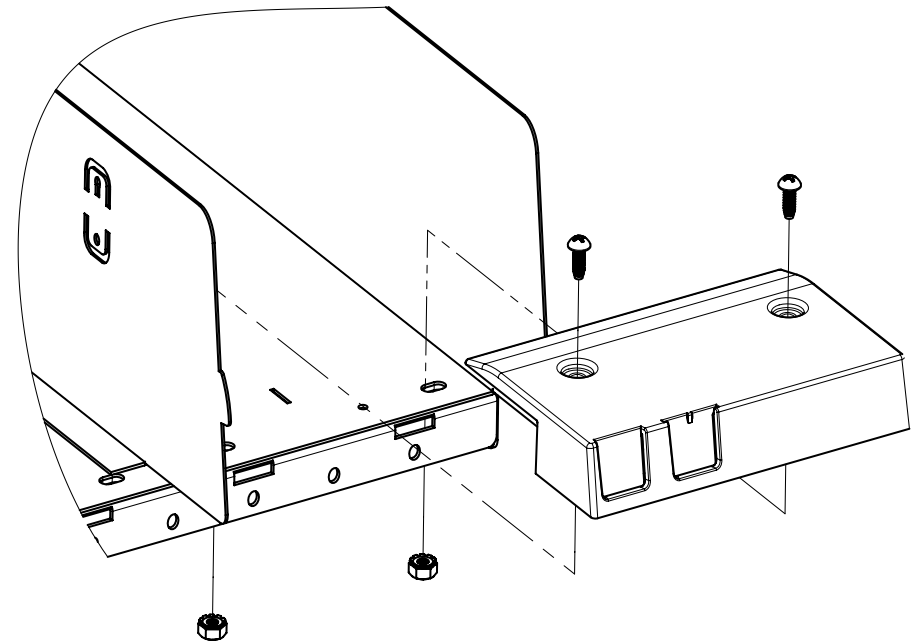
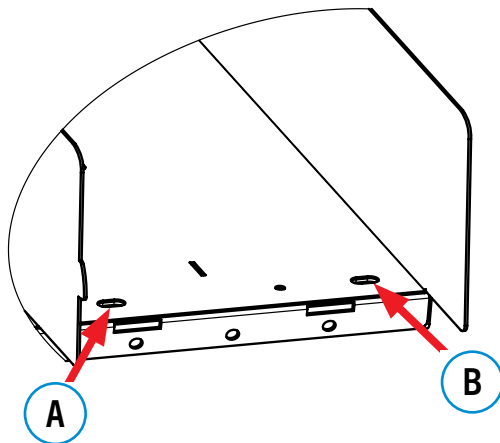
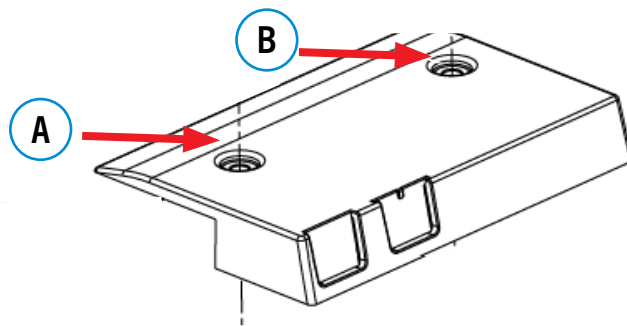

- Align points A and B on the Nose kit so that it aligns with points A and B on the Tray.
- Once Nose kit and tray are aligned use the (8-32) screws and (8-32) Nuts included in the kit to secure the Tray nose to Tray.



# GEAR DRIVE ASSEMBLY KIT INSTRUCTIONS

AP Dual Spiral 6000 - 7000 – Kit No. VE1020858 - Motor

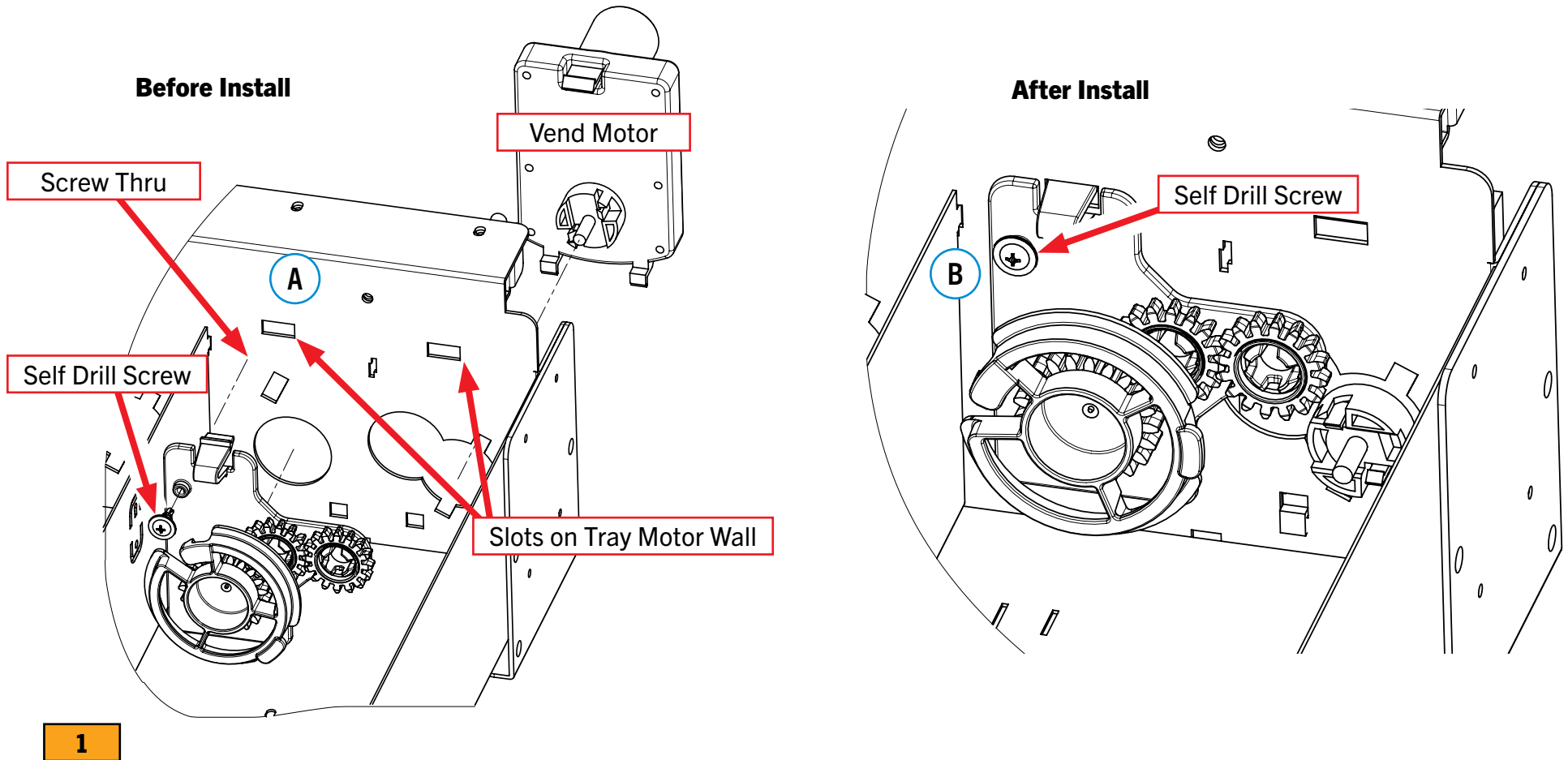

First, insert **Backing Plate with Gears (VE106272)** into the slots in the tray motor slot as shown (A). Using the **Self-Drilling Screw (VE9323B)**, hold the backing plate in position while installing the screw as shown (B).



# GEAR DRIVE ASSEMBLY KIT INSTRUCTIONS

AP Dual Spiral 6000 - 7000 – Kit No. VE1020858 - Motor

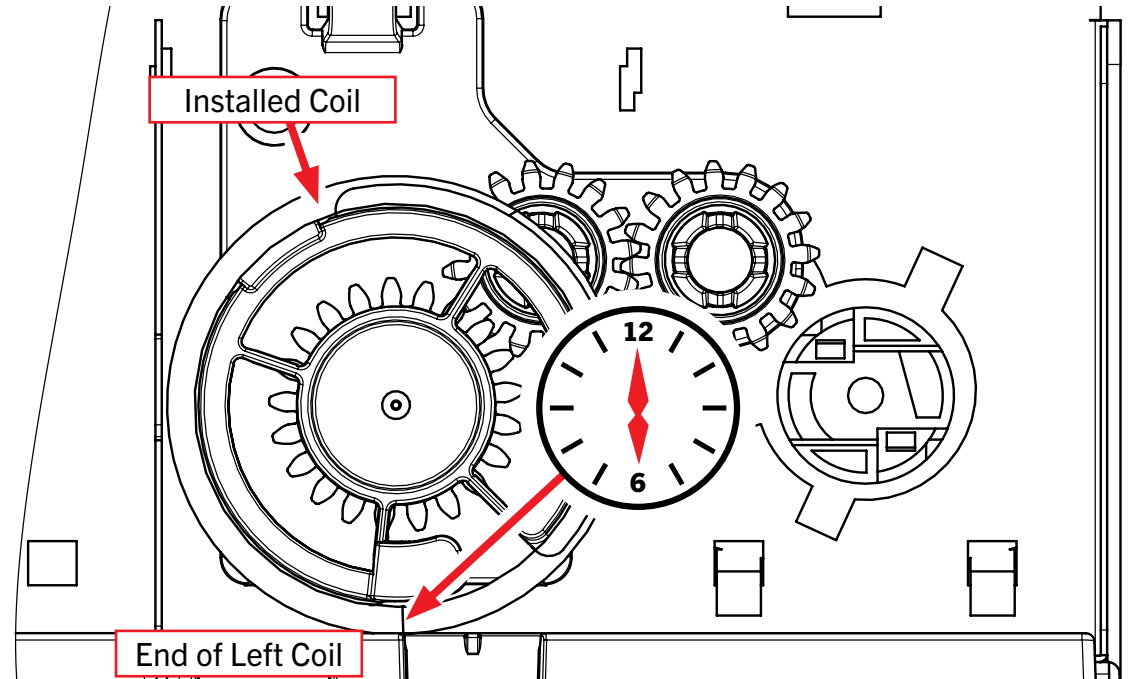
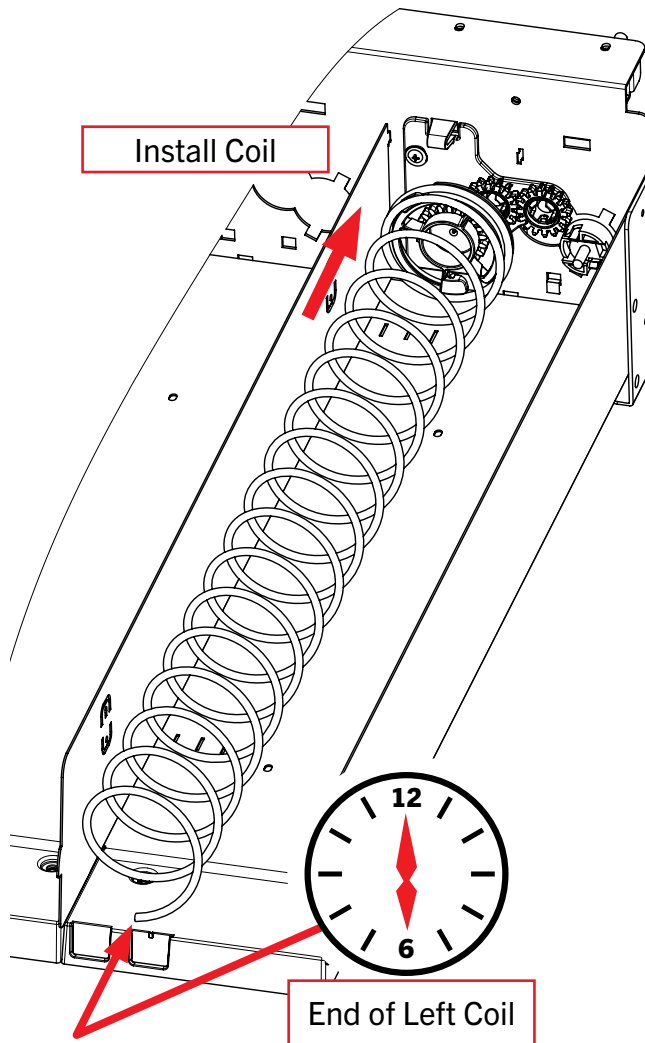

2

Then, install the left coil. Rotate the coil so that the end is at the **6-o'clock position** at the end of the install.



# GEAR DRIVE ASSEMBLY KIT INSTRUCTIONS

AP Dual Spiral 6000 - 7000 – Kit No. VE1020858 - Motor

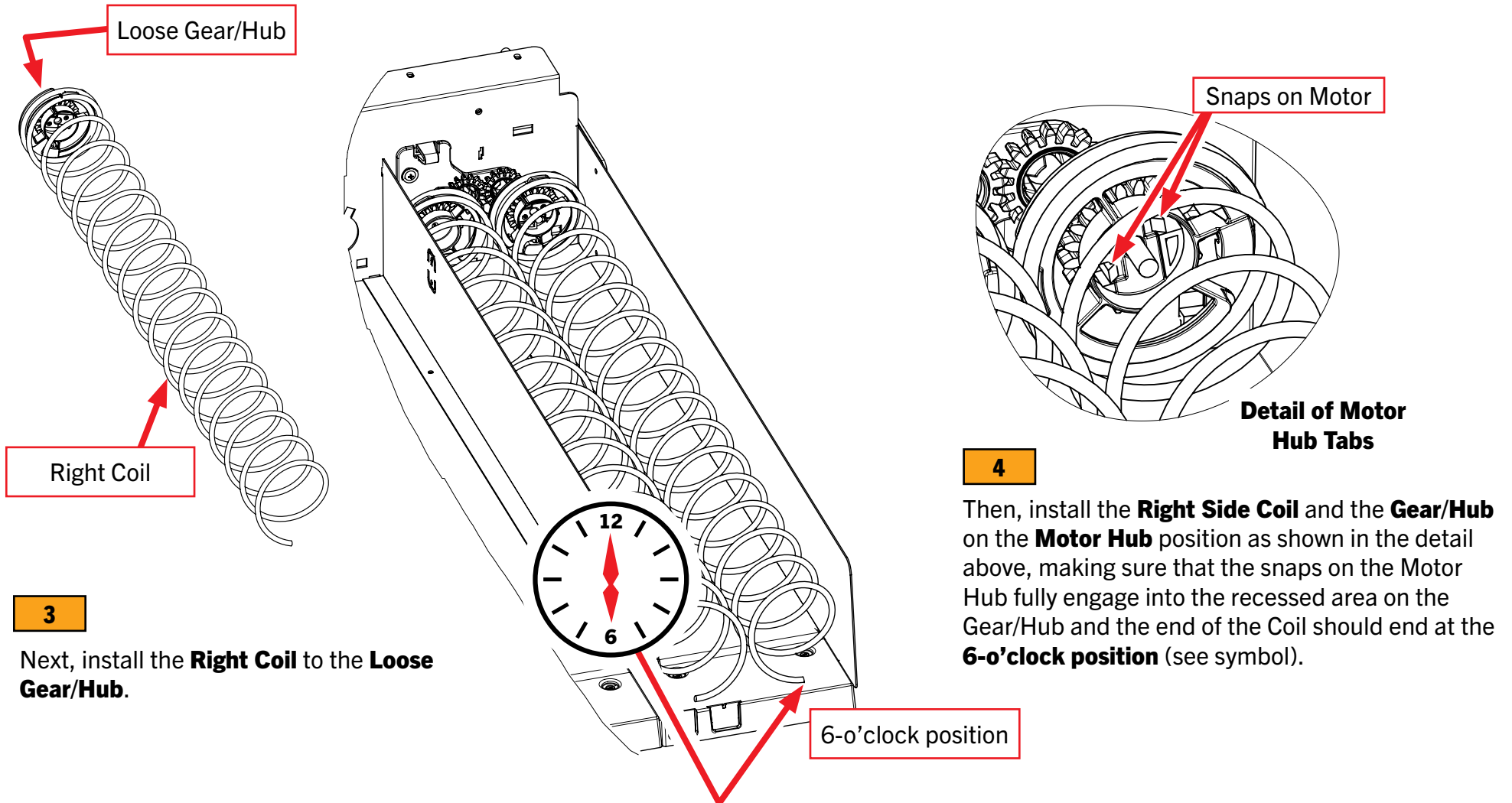



## GEAR DRIVE ASSEMBLY KIT INSTRUCTIONS

*AP Dual Spiral 6000 - 7000 – Kit No. VE1020858 - Motor*

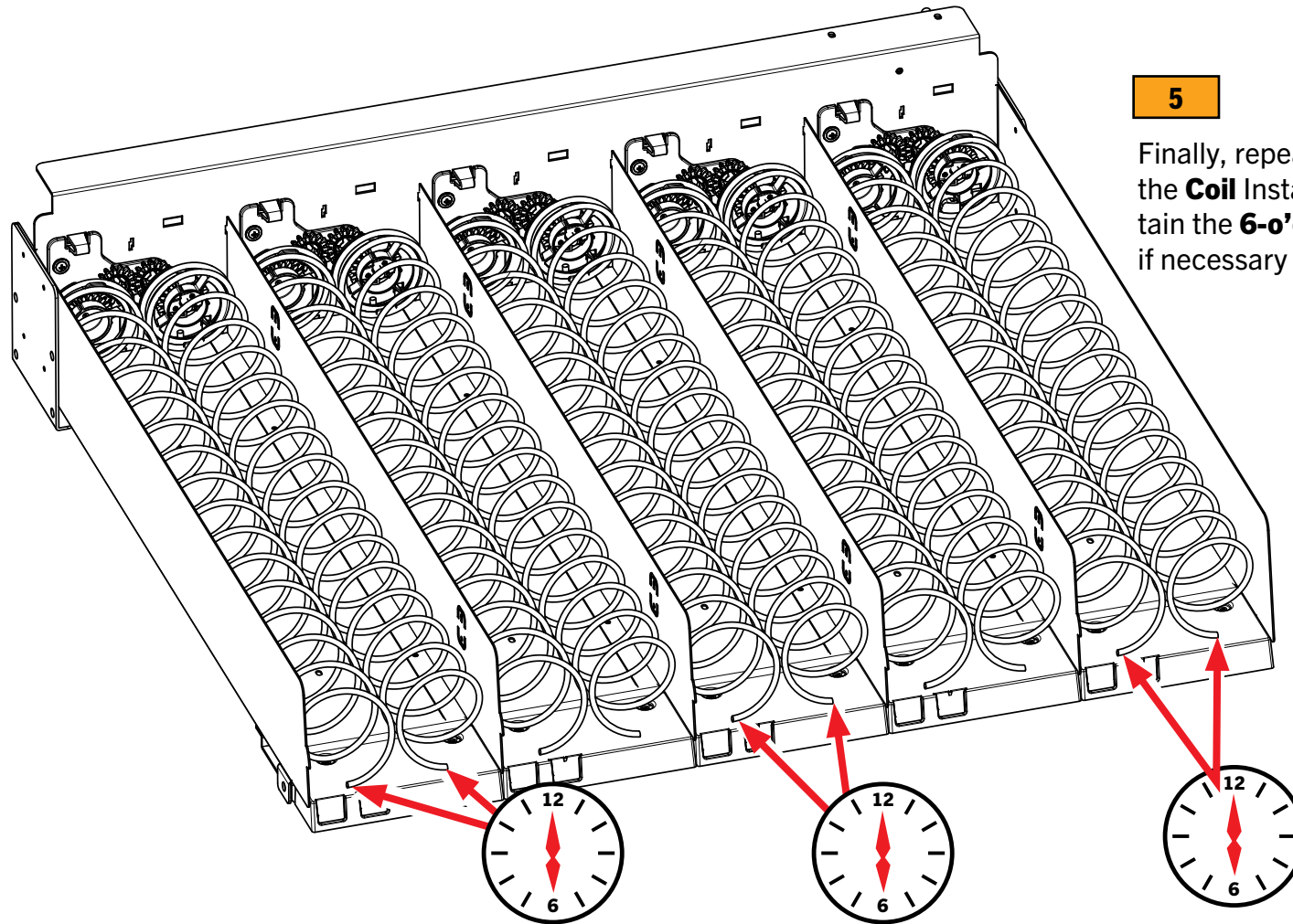

**5**

Finally, repeat steps 2 through 4 to complete the **Coil** Installation. Check the ends to maintain the **6-o'clock** position on each one, adjust if necessary

